

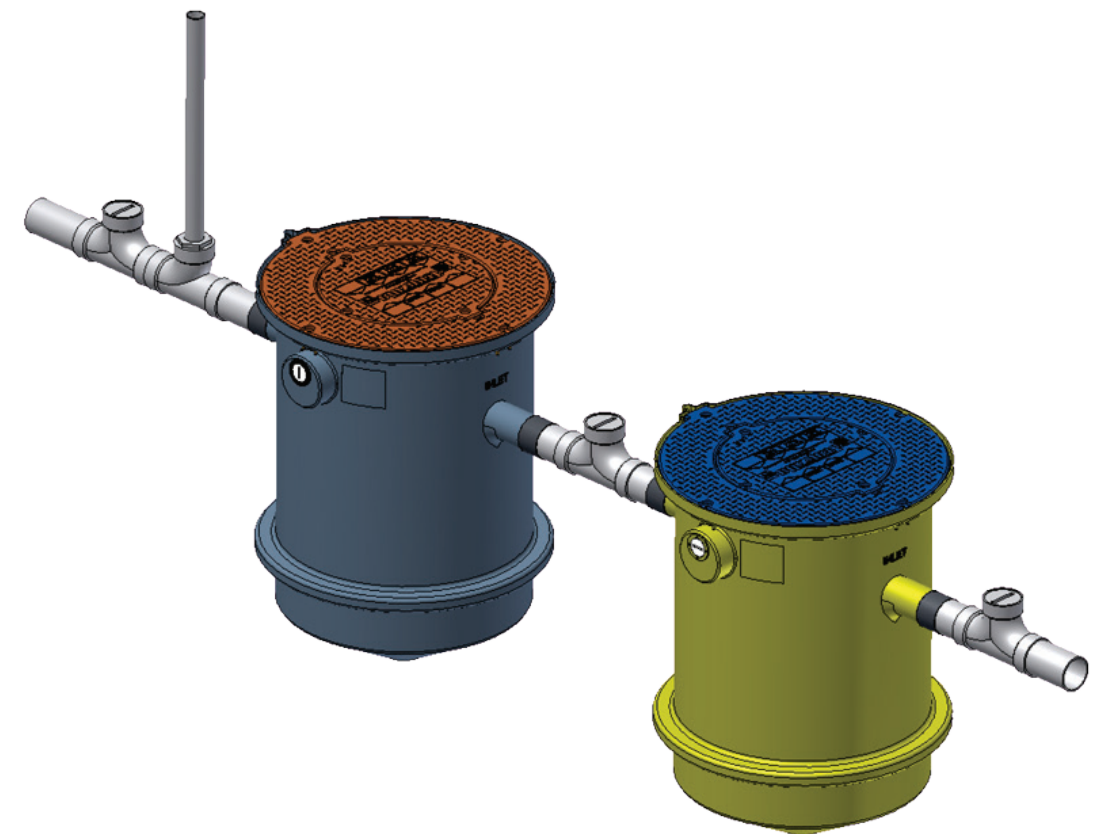

Installation & Maintenance Instructions For Trapzilla® Solids Separators



Trapzilla Solids
Separator

For additional information on Trapzilla or other Thermaco products,
please visit www.trapzilla.com or call at 1-800-633-4204.

Copyright ©2017 Trapzilla® Thermaco, Inc. • P.O.Box 2548 • Asheboro, NC 27204
Toll Free: (800) 633-4204 • Phone: (336) 629-4651 • Fax: (336) 626-5739
info@thermaco.com • www.trapzilla.com

Contents

1.0 System Overview.....	4
2.0 Models and Options.....	5
2.1 In-Ground Models.....	5
2.2 Above-Ground Models.....	6
2.3 Basic Models.....	7
2.4 Options.....	8
3.0 Plumbing Installation.....	9
3.1 Plumbing Considerations Prior to Installation.....	9
3.1.1 Locating the Unit.....	9
3.1.2 Inlet/Outlet Piping.....	9
3.1.3 Flow Controls.....	9
3.1.4 Venting the Outlet.....	9
3.1.5 For High Head Height Applications Over Six (6) Feet (1.95 m).....	9
3.2 Vessel Vent Connection.....	10
3.3 Plumbing Configurations.....	11
3.3.1 Plumbing Installation for One Solids Separator.....	11
3.3.2 Plumbing Installation Two Solids Separators.....	12
3.3.3 One Solids Separator and One Trapzilla.....	13
3.3.4 One Solids Separator and Two Trapzilla Units.....	14
3.3.5 Two Solids Separators and Two Trapzilla Units.....	15
4.0 Above-Ground Installation.....	16
4.1 Components for Above-Ground Installations.....	16
4.2 Instructions for Installing Multiple Trapzilla Units Above-Ground.....	17
5.0 In-Ground Installation Instructions.....	18
5.1 Plumbing Instructions for a Single Solids Separator Installed In-Ground.....	18
5.2 One Solids Separator and One Trapzilla.....	19
5.3 Trimming and Setting the ECA-TSS-18 Single-Piece Extension Collar.....	20
5.4 Concrete Calculations for Solids Separators Models.....	22
6.0 Hanging Installation.....	23
7.0 Unit Maintenance.....	24
7.1 Measuring Solids Levels.....	24
7.2 Pumping/Serviceing Unit.....	25
8.0 Limited Warranty & Remedy.....	26

1.0 System Overview

Thermaco, Inc. also offers the **TSS Trapzilla Solids Separator** that traps incidental kitchen solids upstream of the Trapzilla Grease Interceptor.

The proper installation of a Trapzilla® Supercapacity Solids Separators can reduce or eliminate solids problems and costly sewer surcharges and fines through efficient separation and retention of incidental solids.

The unique compact design of the Trapzilla allows for installation into most facilities. Options are available that enable a Trapzilla unit to be installed on the floor, suspended from the ceiling or in-ground outside the facility.

Trapzilla Solids Interceptor units are designed to treat high flows of kitchen drainwater with large solids storage capacity within a small footprint unit. These units are easy to maneuver into position and just as easy to plumb.

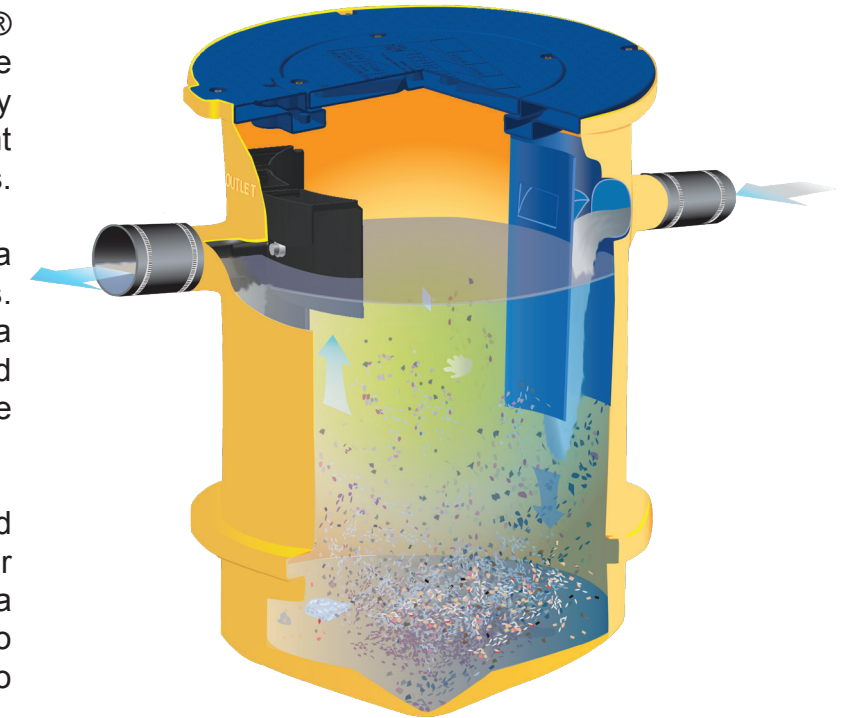

Grease interceptors, grease traps, automatic recovery units, grease removal devices, solids separators and other similar plumbing devices receiving kitchen flows from sinks, floor drains, woks and other food bearing sources may generate odors. There are many factors influencing odor evolution and dissemination. These include room ventilation, kitchen menu, ambient temperatures, ware washing practices, grease/oil input, daily input fluid volume, sanitizers, installation plumbing design and product maintenance/upkeep. Odors are usually prevented by good area ventilation, frequent fluid inputs, good product maintenance practices and proper product installation. Additional steps, including aeration, chlorination, improved area ventilation and additional maintenance control, may be needed at some sites.

2.0 Models and Options

Thermaco offers different models and options specifically designed to assist the owner/installer meet site conditions while complying with local pretreatment and plumbing code.

2.1 In-Ground Models

TSS-95-ECA

95 gallons of solids retention capacity, capable of handling flow rates of up to 150 gpm. Equipped with 4" inlet/outlet, and 2" vessel vent connection.

Comes with: 18" tall Extension Collar Adapter Lid Assembly with 22" diameter lid.

*Model available with 6" Inlet/Outlet, add suffix -6 to model.

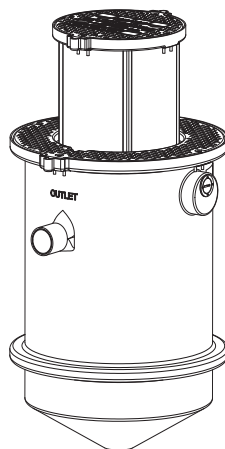

TSS-70-ECA

70 gallons of solids retention capacity, capable of handling flow rates of up to 75 gpm. Equipped with 4" inlet/outlet, and 2" vessel vent connection.

Comes with: 18" tall Extension Collar Adapter Lid Assembly with 22" diameter lid.

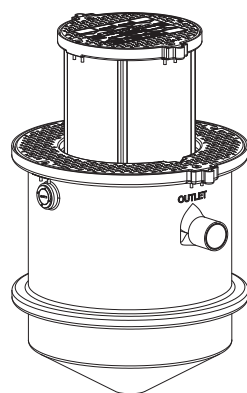

2.2 Above-Ground Models

TSS-95-SSA

95 gallons of solids retention capacity, capable of handling flow rates of up to 150 gpm. Equipped with 4" inlet/outlet, and 2" vessel vent connection.

Comes with: Standard Adapter Top Cover with 22" diameter lid, and SSOP-70/95 for above-ground installation.

*Model available with 6" Inlet/Outlet, add suffix -6 to model.

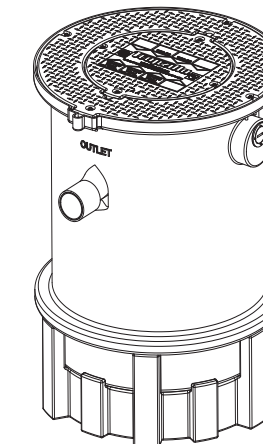

TSS-70-SSA

70 gallons of solids retention capacity, capable of handling flow rates of up to 75 gpm. Equipped with 4" inlet/outlet, and 2" vessel vent connection.

Comes with: Standard Adapter Top Cover with 22" diameter lid, and SSOP-70/95 for above ground installation.

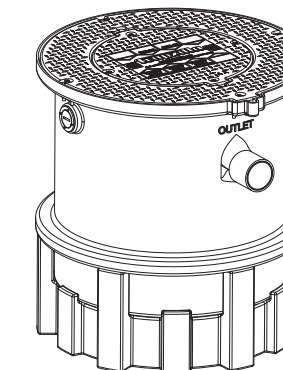

2.3 Basic Models

TSS-95

95 gallons of solids retention capacity, capable of handling flow rates of up to 150 gpm. Equipped with 4" inlet/outlet, and 2" vessel vent connection.

Comes with: Standard Adapter Top Cover with 22" diameter lid.

*Model available with 6" Inlet/Outlet, add suffix -6 to model.

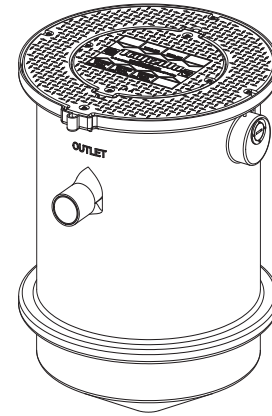

TSS-70

70 gallons of solids retention capacity, capable of handling flow rates of up to 75 gpm. Equipped with 4" inlet/outlet, and 2" vessel vent connection.

Comes with: Standard Adapter Top Cover with 22" diameter lid.

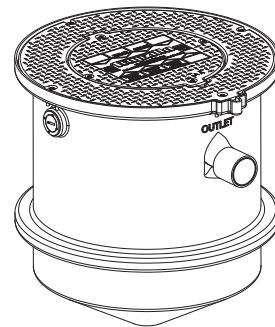

2.4 Options

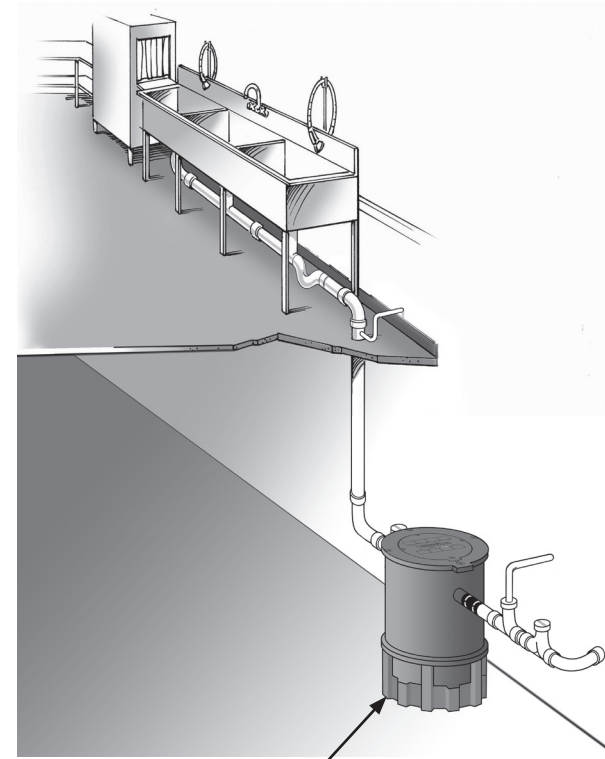

SSOP-70/95
Support Stand for TSS-70 and TSS-95 models
Allows unit to be installed directly on the floor in a basement or mechanical room.
***Included with -SSA Models**

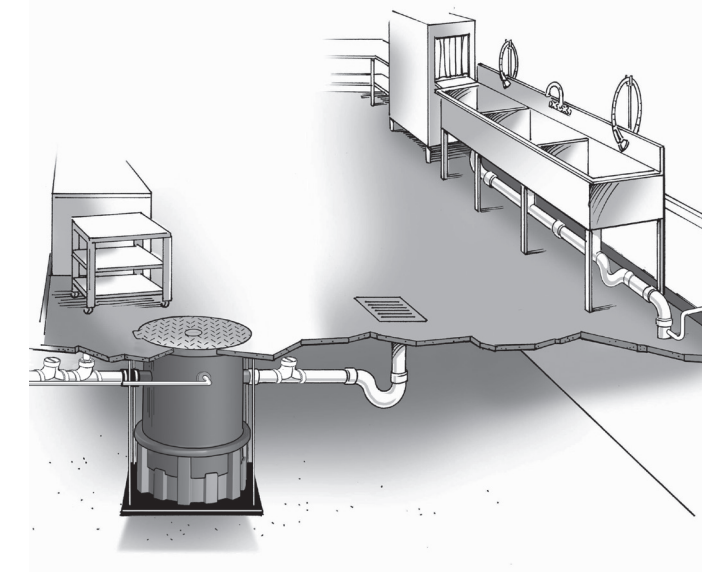

FTCA-36
Fabricated Top Cover Assembly with 36" diameter for additional traction in high foot-traffic areas and 4" Brass cleanout port.

FTCA-22 (not shown)
22" diameter cover available for In-Ground installations.

ECA-TSS-29 (in yellow) for Trapzilla Solids Separators.

These field-modifiable extension collars available to provide additional depth for existing kitchen drainage piping.

-ECA Models ship with built-in 0-18" extension collar.
ECA-TSS-29 adds 0-29" depth to -ECA Models or 5-29" to Base Models.

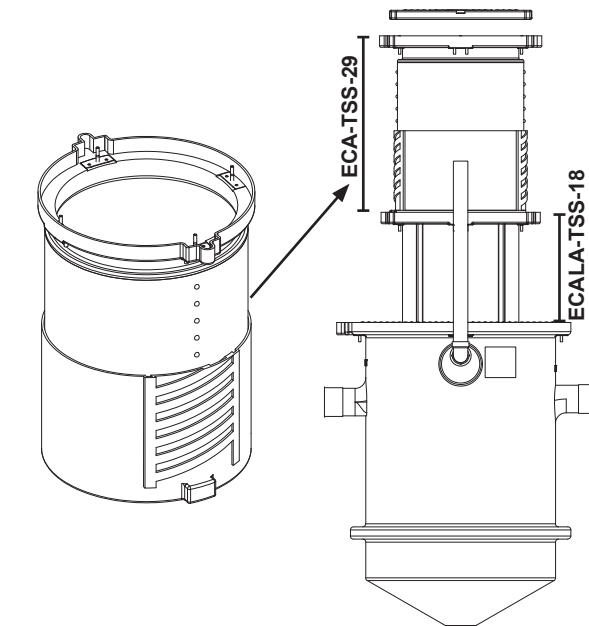

3.0 Plumbing Installation

3.1 Plumbing Considerations Prior to Installation

3.1.1 Locating the Unit

The system should be visible and easily accessible for maintenance and inspection. Options are available to install Trapzilla Solids Separators in a basement, suspended from a ceiling or in-ground in an exterior location. Make sure adequate room is provided around the unit to allow easy access for a pump truck operator. Make sure the height above the Trapzilla access cover is enough to properly service the system.

3.1.2 Inlet/Outlet Piping

The inlet and outlet piping connections require flexible sleeve pipe couplings. Keep outlet piping as straight as possible. Thermaco, Inc. recommends installation of Two-Way Cleanouts on both the Inlet and Outlet of Trapzilla Interceptors and Solids Separators in accordance with all applicable laws, regulations and codes. **These cleanouts should match the size of the Inlet and Outlet Piping (i.e. for 4" plumbing, a 4" cleanout should be used).** Use only "sweep" connections. Do not reduce the pipe sizing on the outlet piping. Do not install "P" trap on outlet connection of system. (Note: The system already has a internal gas trap)

3.1.3 Flow Controls

Trapzilla Grease Interceptors are supplied with a Low-Head Flow Control module (LHFC). These modules are NOT INCLUDED WITH TSS models. If a Trapzilla Solids Separator is being installed with a Trapzilla Grease Interceptor, the LHFC should be connected to the inlet of the Trapzilla Solids Separator in situations where flow rate needs to be restricted to the ASME rated flow or when vented flow control is required by local code.

3.1.4 Venting the Outlet

An outlet vent or approved air admittance valve of at least 1/2 the diameter of the system's outlet connection must be present as close as possible to the Trapzilla outlet to prevent possible siphonage problems. The Vent on the Outlet piping is to be installed in accordance with all applicable laws, regulations and codes. Failure to provide a vent for the system voids Thermaco's Limited Warranty for the system.

3.1.5 For High Head Height Applications Over Six (6) Feet (1.95 m)

For installations where there is head height of greater than 6 feet (1.95 meters), Thermaco, Inc. recommends installation of a code-approved Vented Flow Control Assembly.

3.2 Vessel Vent Connection

Venting of the Trapzilla tank is recommended by the manufacturer and required for indoor installations.

•Vent the tank through the provided 2" NPT threaded connector on the side of the tank (This vent may be located above the outlet or on the side of the tank depending on model).

•Remove and discard the 2" plug and connect 2" vent lines as indicated below.

**Models with 6" Inlet/Outlet have 3" NPT vessel vent

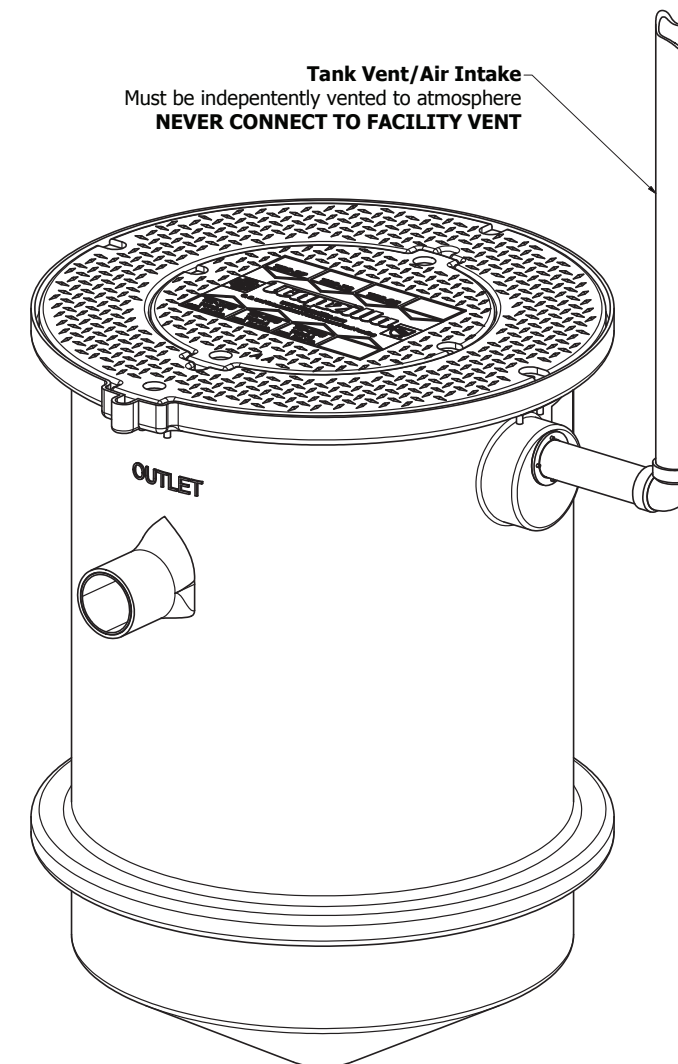

Note: Drawing for reference only. Equipment must be installed in compliance with all applicable laws, regulations and codes, including plumbing codes. Installation should be performed by a qualified plumber.

3.3 Plumbing Configurations

3.3.1 One Solids Separator

Trapzilla Solids Separators DO NOT ship with a Low Head Flow Control module. If needed, it may be purchased separately and installed to the inlet of the Trapzilla and connected to a code-approved air intake.

Thermaco, Inc. recommends installation of 4" (100 mm) Two-Way Cleanouts on both the Inlet and Outlet of Trapzilla® Models TSS-70 and TSS-95 in accordance with all applicable laws, regulations and codes. A Vent on the Outlet piping is also to be installed in accordance with all applicable laws, regulations and codes.

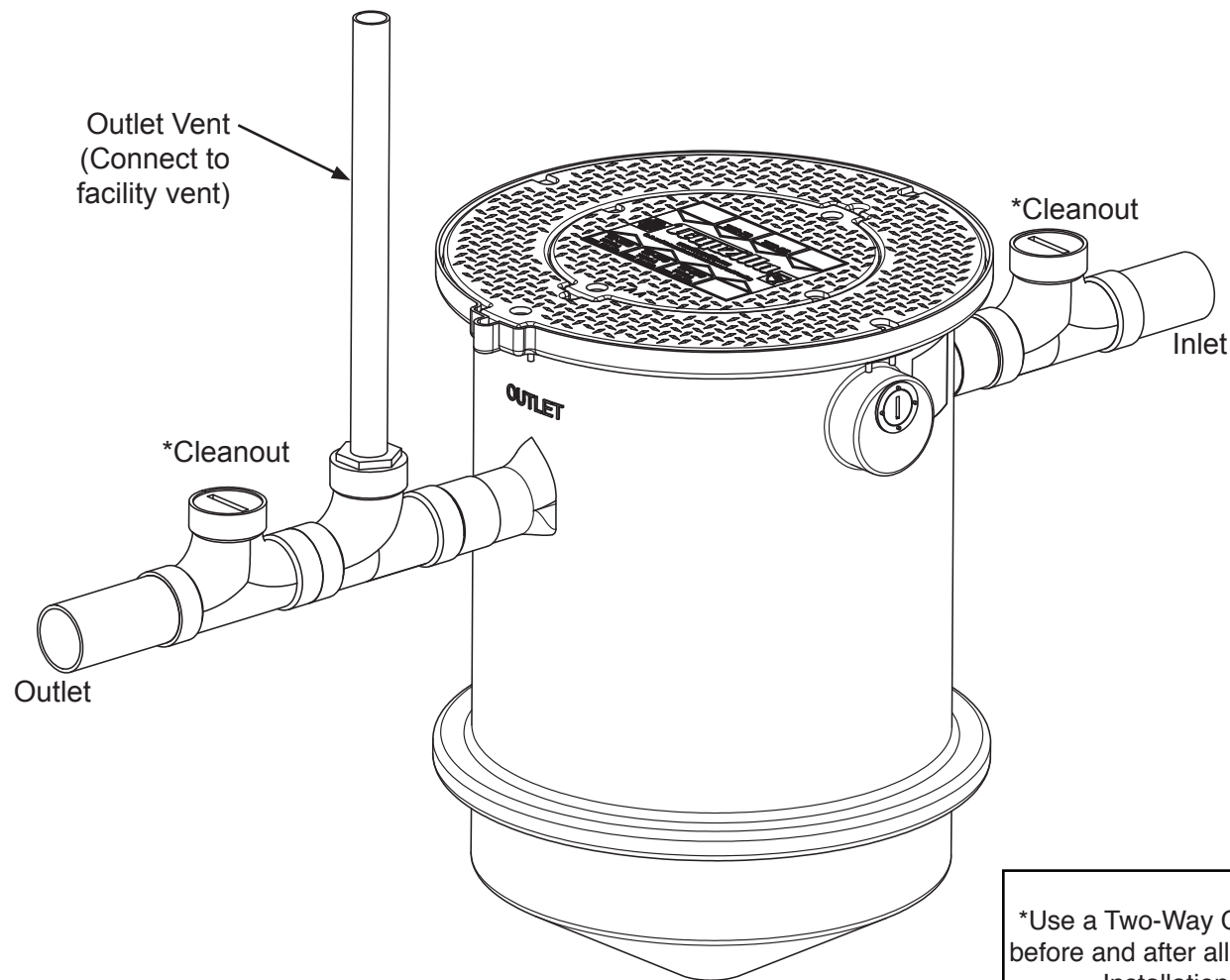

*Use a Two-Way Cleanout before and after all Trapzilla Installations

Note: Drawing for reference only. Equipment must be installed in compliance with all applicable laws, regulations and codes, including plumbing codes. Installation should be performed by a qualified

3.3.2 Two Solids Separators

Two Trapzilla Solids Separators should be installed in parallel with a Flow Splitter diverting the flow. Place Two-Way Cleanouts before, between and after the units as shown below, including before and after the flow splitter. Make sure to connect an outlet vent after each Trapzilla Grease Interceptor. If needed, a Low Head Flow Control (LHFC) may be purchased separately and should only be installed after the first Cleanout and before the 4" Flow Splitter.

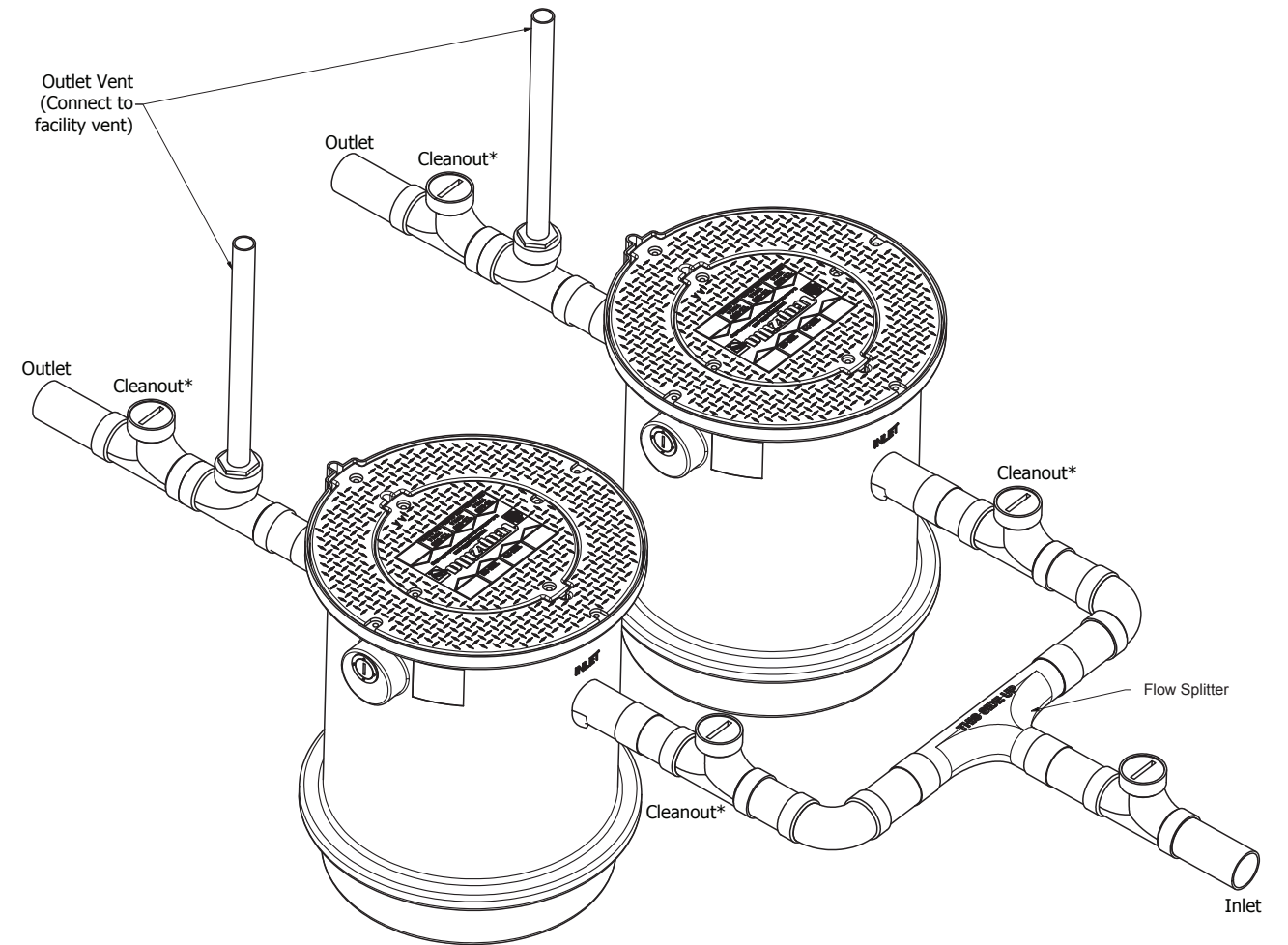

*Use a Two-Way Cleanout before and after all Trapzilla Installations

Note: Drawing for reference only. Equipment must be installed in compliance with all applicable laws, regulations and codes, including plumbing codes. Installation should be performed by a qualified

3.3.3 One Solids Separator and One Trapzilla

A single Trapzilla Solids Separator and Trapzilla Grease Interceptor should be installed in series. Place Two-Way Cleanouts before, between and after the units as shown below. Make sure to connect an outlet vent after the Trapzilla Grease Interceptor. If needed, a Low Head Flow Control (LHFC) is included with Trapzilla Grease Interceptors (Not included with Solids Separators) or may be purchased separately and should only be installed after the first Cleanout and before the 4" Flow Splitter.

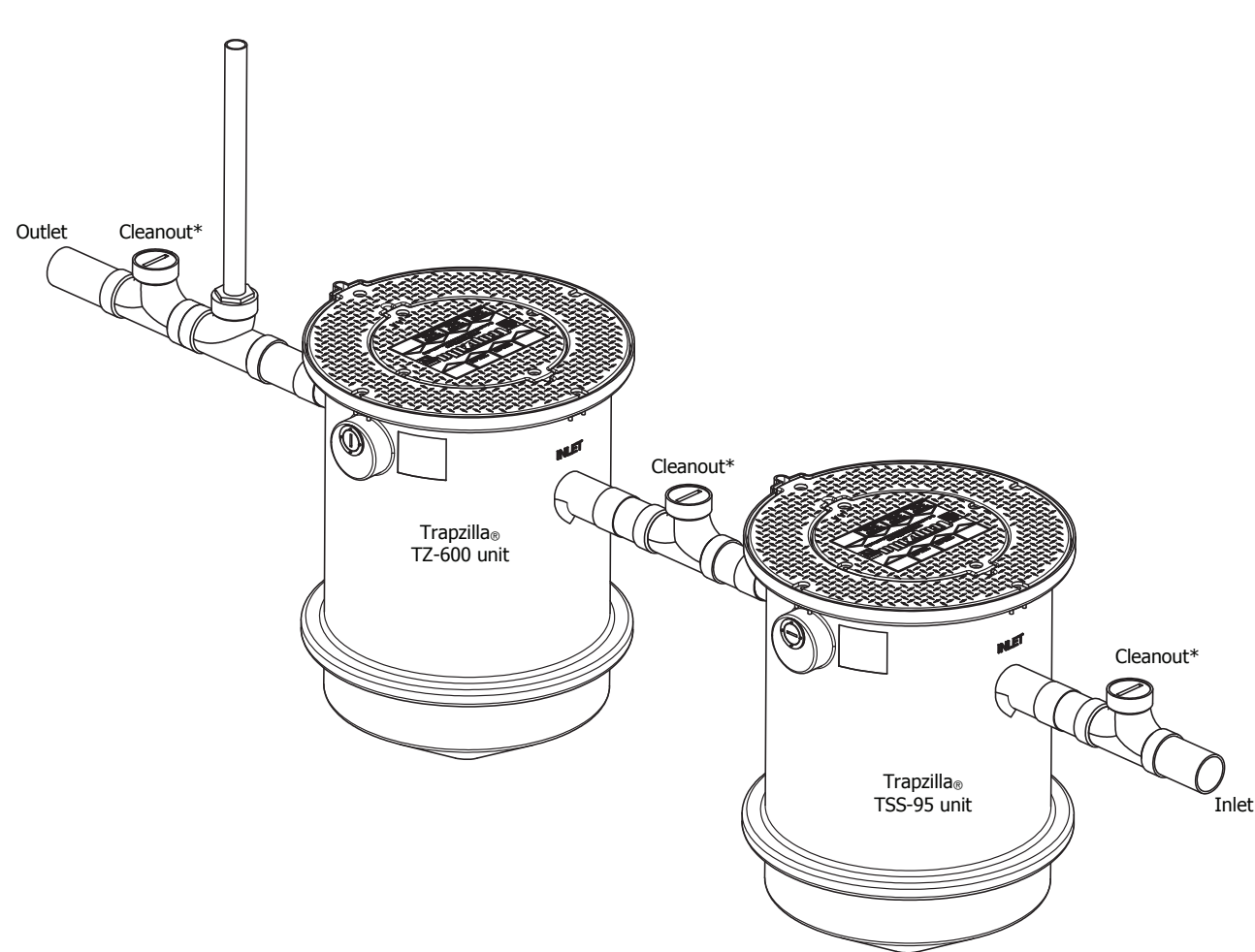

*Use a Two-Way Cleanout before and after all Trapzilla Installations

Note: Drawing for reference only. Equipment must be installed in compliance with all applicable laws, regulations and codes, including plumbing codes. Installation should be performed by a qualified

3.3.4 One Solids Separator and Two Trapzilla Units

A single Trapzilla Solids Separator and two Trapzilla Grease Interceptors should be installed by placing the Solids Separator in line and then using a Flow Splitter to divert the water flow to two separate Trapzilla units in parallel. Place Two-Way Cleanouts before, between and after the units as shown below, including before and after the flow splitter. Make sure to connect an outlet vent after the Trapzilla Grease Interceptor. If needed, a Low Head Flow Control (LHFC) is included with Trapzilla Grease Interceptors (Not included with Solids Separators) or may be purchased separately and should only be installed after the first Cleanout and before the 4" Flow Splitter.

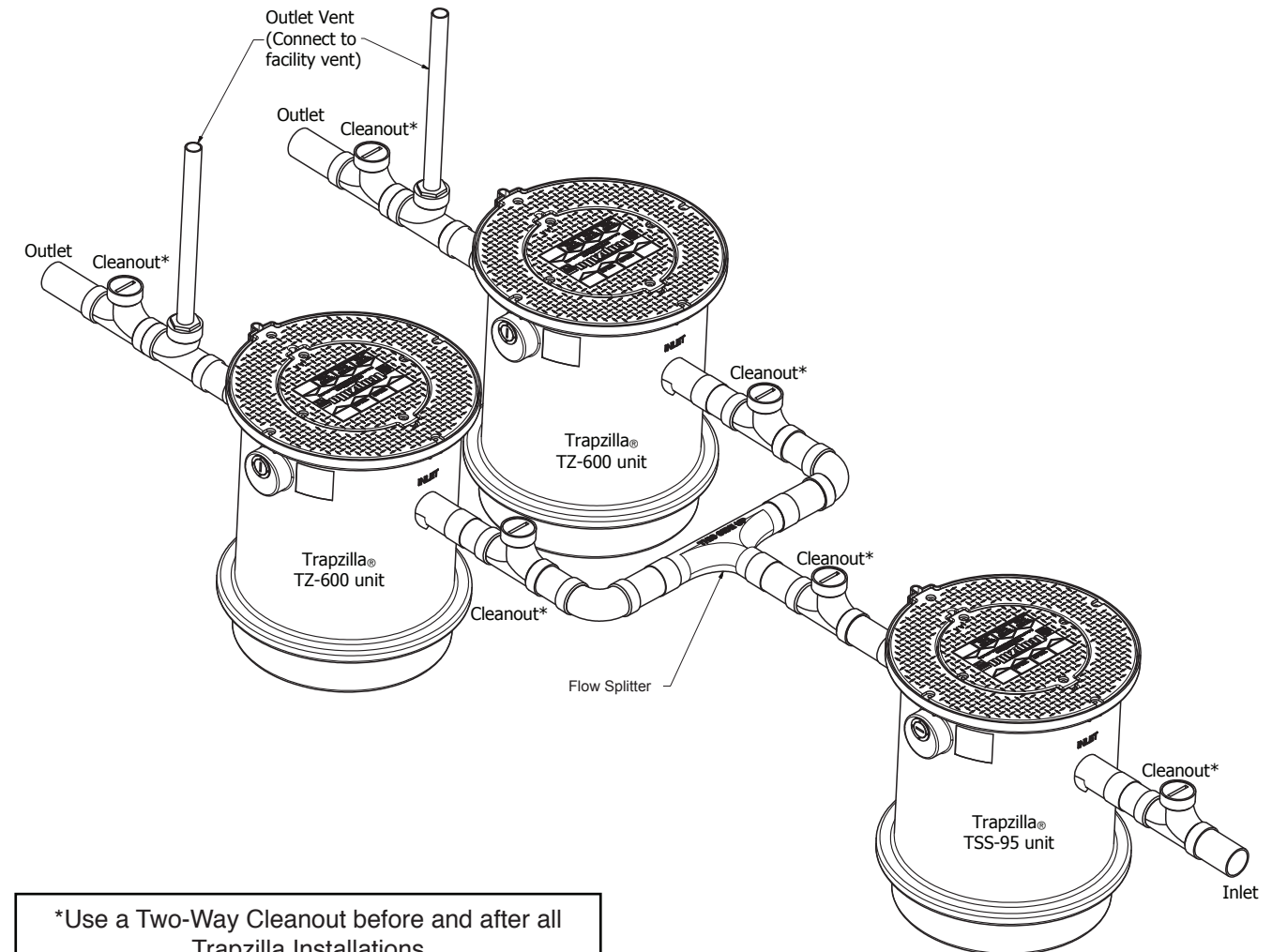

*Use a Two-Way Cleanout before and after all Trapzilla Installations

Note: Drawing for reference only. Equipment must be installed in compliance with all applicable laws, regulations and codes, including plumbing codes. Installation should be performed by a qualified

3.3.5 Two Solids Separators and Two Trapzilla Units

Two Trapzilla Solids Separator and two Trapzilla Grease Interceptors should be installed by placing a Flow Splitter to divert the water flow to two separate Solids Separators and Trapzilla units in parallel. Place Two-Way Cleanouts before, between and after the units as shown below, including before and after the flow splitter. Make sure to connect an outlet vent after the Trapzilla Grease Interceptor. If needed, a Low Head Flow Control (LHFC) is included with Trapzilla Grease Interceptors (Not included with Solids Separators) or may be purchased separately and should only be installed after the first Cleanout and before the 4" Flow Splitter.

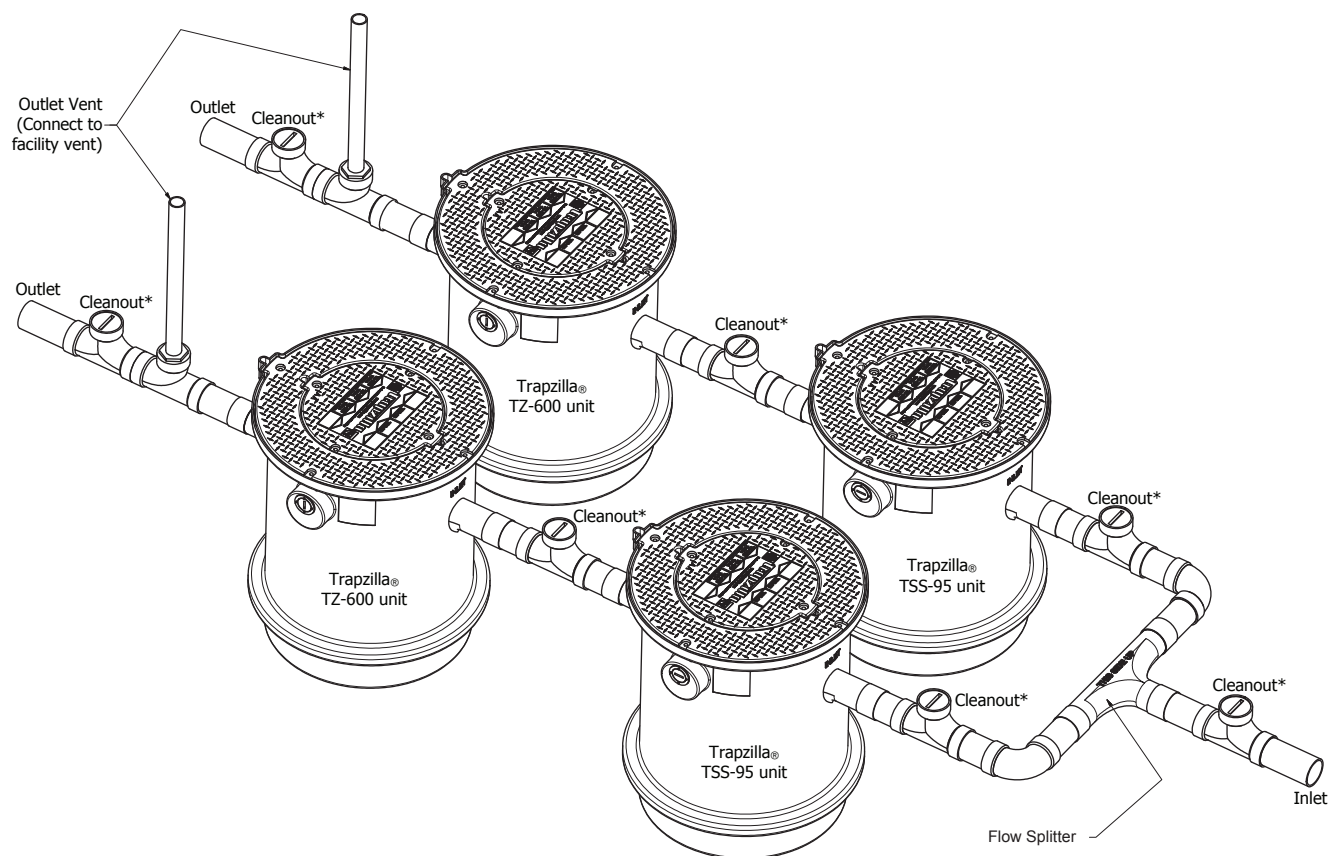

*Use a Two-Way Cleanout before and after all Trapzilla Installations

Note: Drawing for reference only. Equipment must be installed in compliance with all applicable laws, regulations and codes, including plumbing codes. Installation should be performed by a qualified

4.0 Above-Ground Installation

4.1 Components for Above-Ground Installations

Using a Support Stand, a Trapzilla Solids Separator may be installed directly on top of the floor in a location such as a basement or mechanical room.

The SSOP-70/95 should be used with Models TSS-70 and TSS-95.

***This item ships with all -SSA models.**

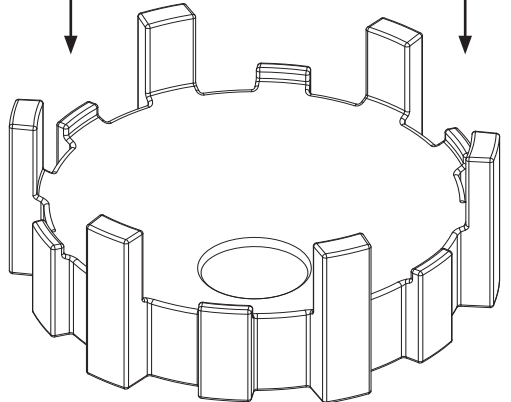
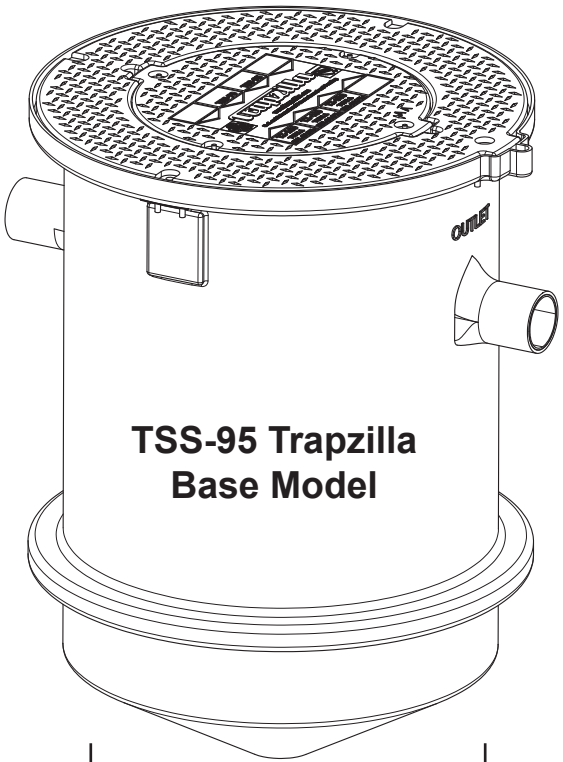

NOTE: SUPPORT STAND MUST BE INSTALLED OVER A CONTINUOUS SURFACE. NON-CONTINUOUS SURFACES SUCH AS GRATES ARE NOT SUITABLE FOR SUPPORT.

SSOP-70/95 Support Stand

The SSOP Support Stand is a one-piece assembly with a conical center that sits on the floor. It does not add appreciable height to the assembly.

4.2 Instructions for Installing Multiple Trapzilla Units Above-Ground

When installing multiple Trapzilla units in series, the change in elevation from the inlet to the outlet of a unit requires that each preceding unit be installed 1" higher than the unit after it. For above-ground units, pressure treated plywood may be placed fully beneath the support stand to create the height difference.

All installations inside of a building must have a vessel vent installed and piped to atmosphere.

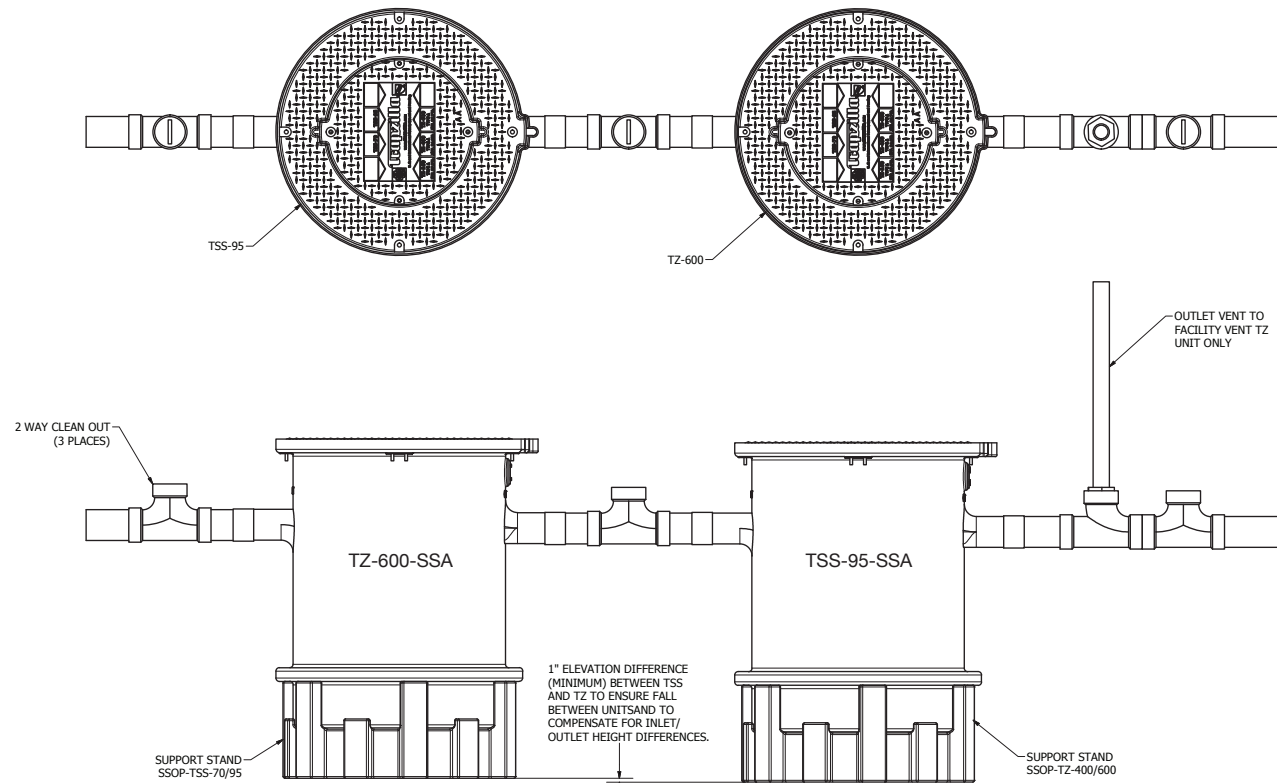

5.0 In-Ground Installation Instructions

5.1 Plumbing Instructions for a Single Solids Separator Installed In-Ground

Trapzilla units may also be installed in the ground outside of the facility. For instances where the facility drainage piping requires an extension collar that is no more than 18", use the instructions for the full TSS-95-ECA unit. If the unit is to be deeper in the ground, the ECA-TSS-29 Extension Collar Assembly may be installed to align the Trapzilla inlet with the drainage piping. The ECA-TSS-29 may be trimmed in the field to fit. Trim both the inner and outer portions of the extension collar to make shorter than collapsed height. Thermaco, Inc. also recommends embedding the in-ground Trapzilla with concrete to provide additional structural strength and to off set buoyancy effects. For Buoyancy Calculations & suggested concrete fill quantities please see the following page. Use the full TSS-95-ECA for 0-18" of collar needed or purchase separately the TSS-95 and ECA-TSS-29 for 5-29" of collar needed.

In-Ground Installations inside of a building must have a vessel vent installed and piped to atmosphere.

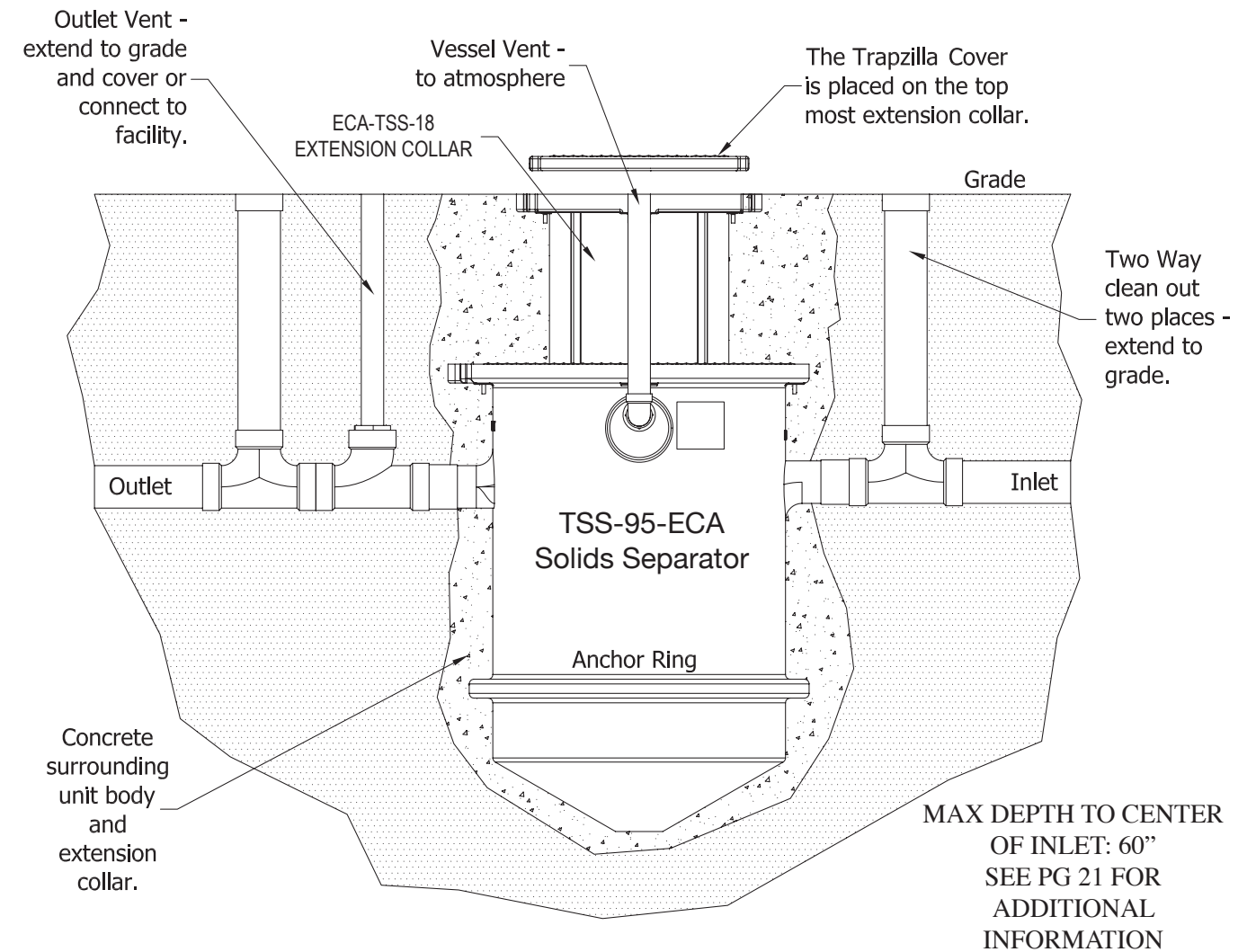

* Units using additional extension collars must use adapter lid and/or extension collars included with unit.

5.2 One Solids Separator and One Trapzilla

When installing multiple Trapzilla units in series, the change in elevation from the inlet to the outlet of a unit requires each preceding unit to be installed 1" higher than the unit after it.

In-Ground Installations inside of a building must have a vessel vent installed and piped to atmosphere.

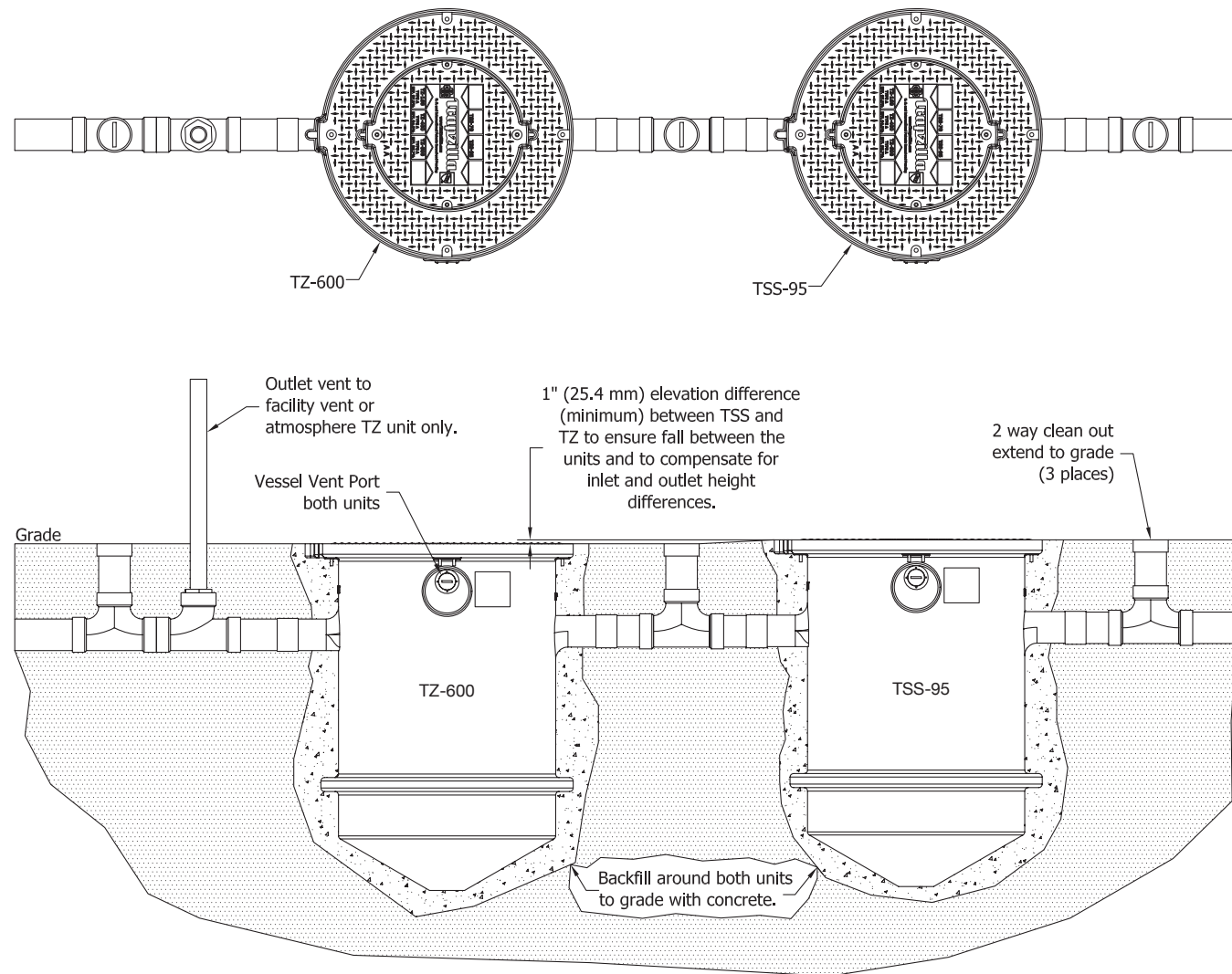

* Units using additional extension collars must use adapter lid and/or extension collars included with unit.

5.3 Trimming and Setting the ECA-TSS-18 Single-Piece Extension Collar

In-Ground Trapzilla Solids Separator Models ship with a built-in, single-piece, 18" extension collar that must be trimmed and then set to the correct height to bring the Solid Top Cover to grade.

Follow the steps below to set the extension collar prior to backfilling the hole with concrete.

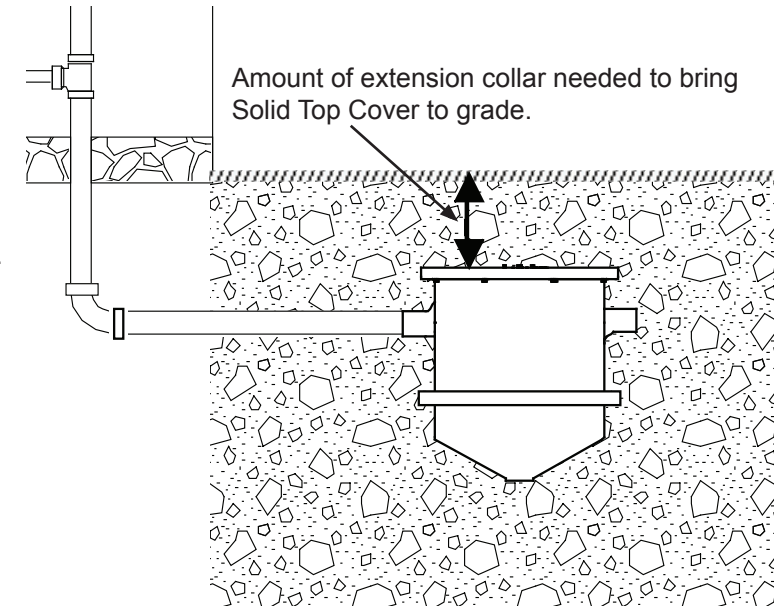

Step 1: With the Solids Separator installed in its permanent location, raise the telescoping extension collar to finished grade or floor level. Measure the height from the top of the unit to this finished extension collar height and record this dimension.

Note: If the floor will have a tile covering allow for the tile thickness when determining the extension collar height.

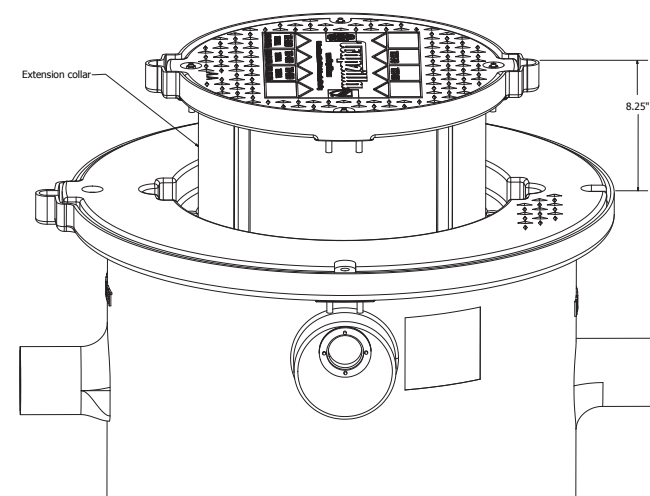

Step 2: Remove the extension collar adapter ring from the unit with the extension collar still in place. On the underside of the cover, mark the excess extension collar length at the bottom of the four (4) "skirt" portions of the adapter ring. Check the extension collar height dimension frequently during this marking to ensure that the collar has not moved. Extend this mark between the gaps in the "skirt" so that the collar is marked all around.

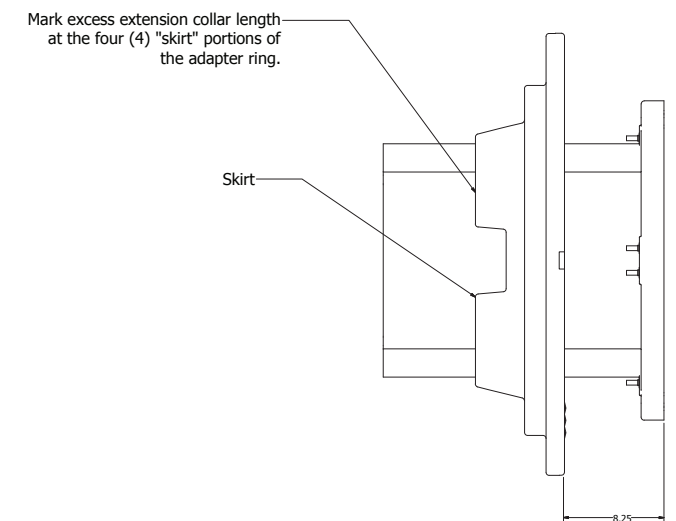

Step 3: Remove the extension collar from the adapter ring and, with an appropriate saw, cut along the line created in Step 2 to remove the excessive extension collar.

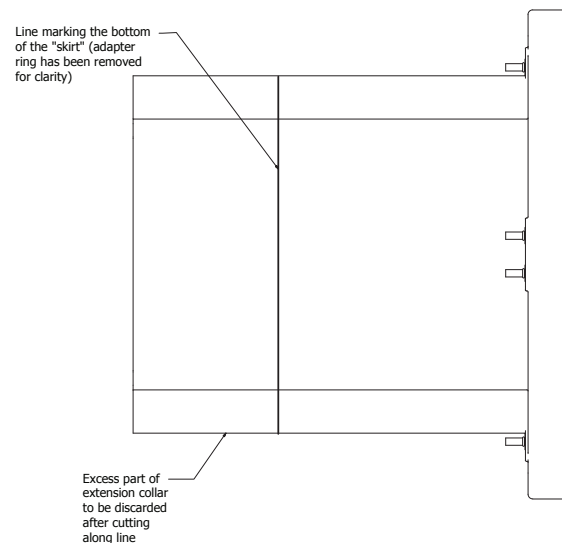

Step 4: Reinsert the extension collar into the adapter ring ensuring that the cover alignment key on the extension collar is aligned with its recess in the adapter ring. Reset the extension collar height to the dimension determined in Step 1.

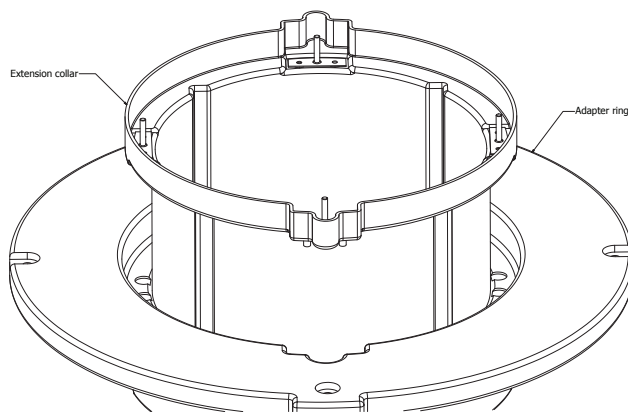

Step 5: Working from the bottom of the assembly, install eight (8) self-drilling, self-tapping screws (provided) through the extension collar wall and into the adapter ring. Two of these screws should be installed in each of the four (4) skirt areas of the adapter ring. Check the extension collar height dimension frequently during this operation to ensure that the collar has not moved. Note: Use caution when tightening these screws to ensure that they do not strip.

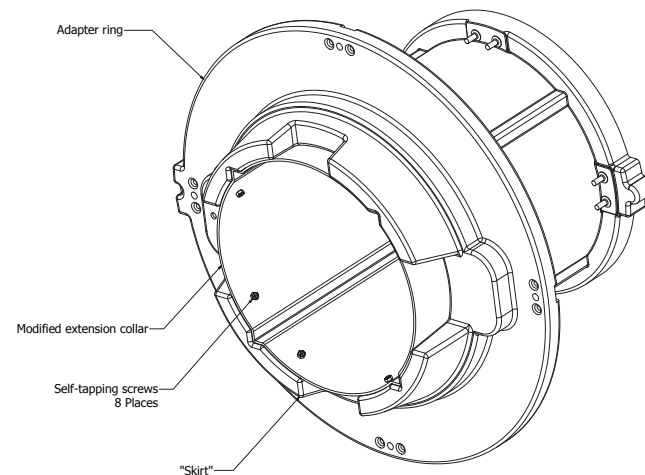

Step 6: Place the adapter ring/extension collar assembly onto the unit. Position the small cover onto the extension collar. Secure the adapter ring and the small cover with the brass nuts and flat washers provided.

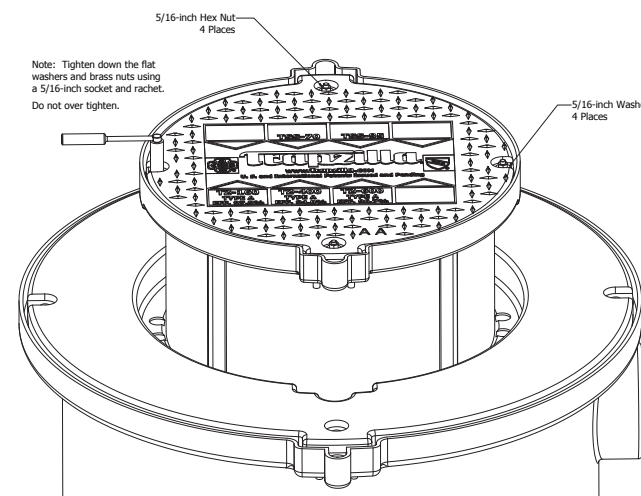

5.4 Concrete Calculations for Solids Separators Models

In order to offset the effects of buoyancy caused by groundwater (high water tables), Thermaco, Inc. recommends concrete be poured around the anchor ring and the Trapzilla® units installed in-ground. The amount of concrete to be used is specified in the table below. The concrete is to be poured continuously and completely surrounding the Trapzilla® Solids Separator (and Extension Collars if applicable) to ensure proper strength and security.

Buoyancy Calculations TSS Models/Components

TSS Model	Amount of Concrete	
	Weight (lbs.)	Volume (Cu. Yards)
TSS-95-ECA	1975	0.50
TSS-70-ECA	1525	0.40
ECA-TSS-29*	600	0.20

* AMOUNT OF CONCRETE TO BE ADDED FOR EACH EXTENSION COLLAR

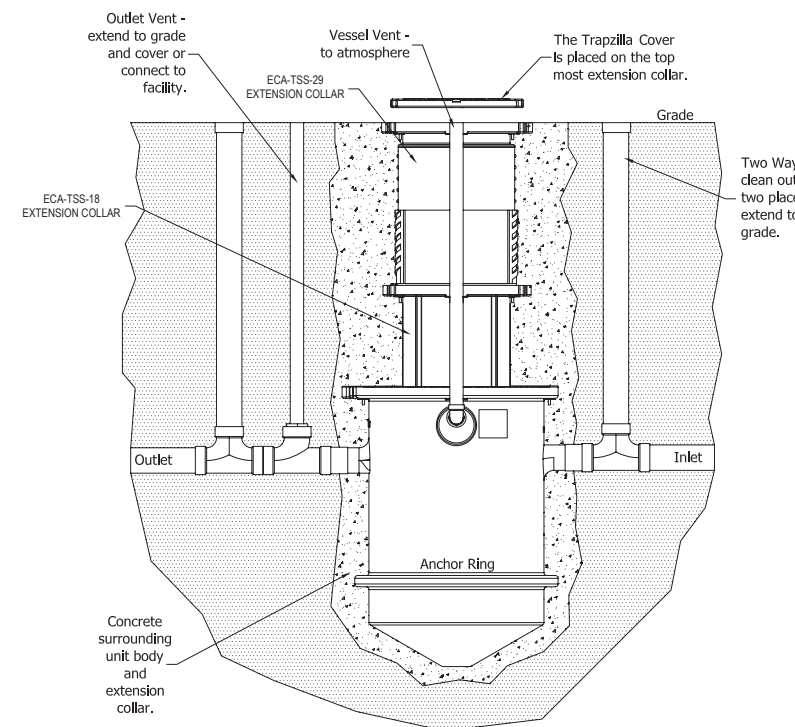

Pictured Left:

Installation of TSS-95-ECA unit with Built-In 18" Extension Collar fully extended and 29" Two-Piece Extension Collar fully extended for a total of 47" of additional depth for unit. Concrete should fully encircle the unit up to the surface. A small amount of space (up to 4") may be left unfilled to cover with dirt and grass if installed outside.

WARNING: PROPER INSTALLATION INSTRUCTIONS MUST BE FOLLOWED FOR THERMACO WARRANTY TO BE VALID. MAXIMUM INSTALLATION DEPTH PERMITTED FOR TRAPZILLA GREASE INTERCEPTORS AND SOLIDS SEPARATORS IS 60" MEASURING FROM CENTER OF INLET TO SURFACE. ANY INSTALLATION DEEPER THAN THIS VOIDS THE WARRANTY FOR THE UNIT. CONTACT THERMACO REGARDING INSTALLATIONS EXCEEDING THIS

6.0 Hanging Installation

Using the HA-70/95 model, a Trapzilla unit may be suspended from a ceiling below the floor of a kitchen or other room.

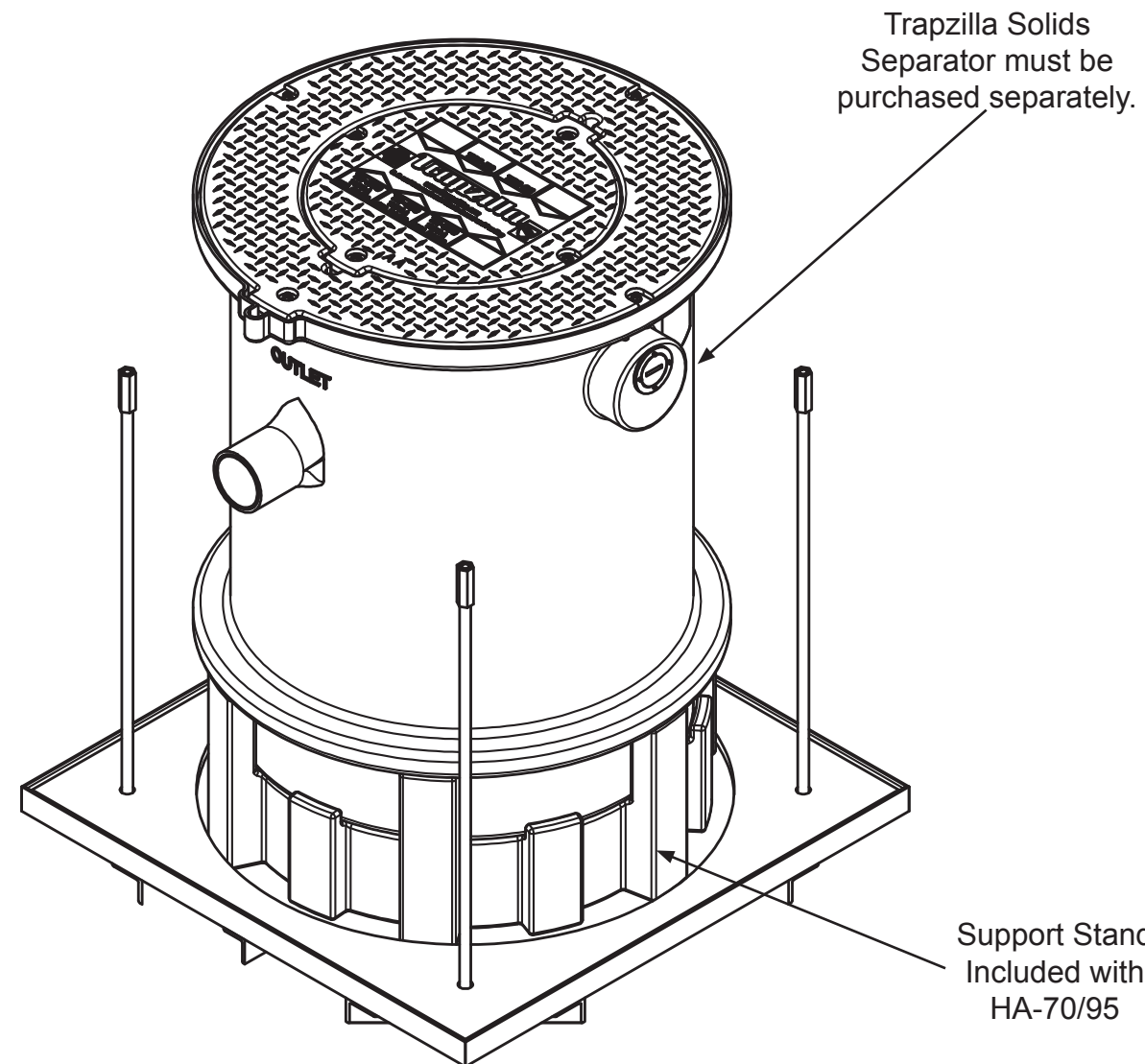

Thermaco, Inc. supplies the frame and SSOP-70/95 with the HA-70/95. This kit needs to be installed by a licensed contractor. The contractor is responsible for determining weight loads, preparation of the floor for installation and any construction necessary for installation of the suspension kit.

Note: Drawing for reference only. Equipment must be installed in compliance with all applicable laws, regulations and codes, including plumbing codes. Installation should be performed by a qualified

7.0 Unit Maintenance

7.1 Measuring Solids Levels

Trapzilla Solids Separators are capable of retaining high quantities of solids in a compact footprint. To determine the current levels of solids in your Trapzilla Solids Separator, follow the instructions below.

1. Remove four nuts/washers securing the Solid Top Cover. Note the size of the unit which is marked on the cover by a metal plate.
2. Place a grease/sludge dipstick into the center of the unit, making sure that it goes all the way to the bottom.
3. Once the dipstick has found its natural resting place at the lowest point in the conical shaped bottom, take the measurement.
4. Remove dipstick and compare sludge levels to the corresponding unit in the charts below.

	Solids	
	Total Capacity:	Ready to pump at:
TSS-95	32"	27"
TSS-70	24"	21"

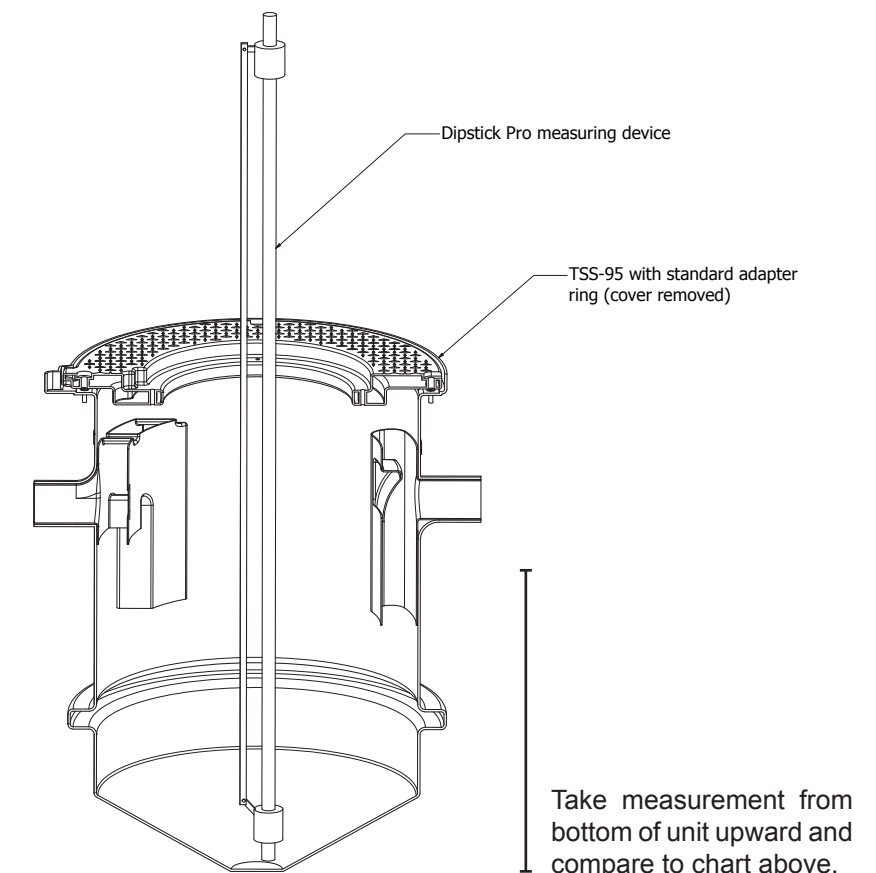

7.2 Pumping/Servicing Unit

Periodically, the Trapzilla® Solids Separator will need to be serviced which involves pumping out the accumulated grease & solids. Each lid has four brass nuts securing the lid. Fully remove the 22" lid to access the solids. Begin by taking the solids from the top of the tank. Be sure to lower the hose all the way to the bottom of the Trapzilla unit so that solids may be entirely removed.

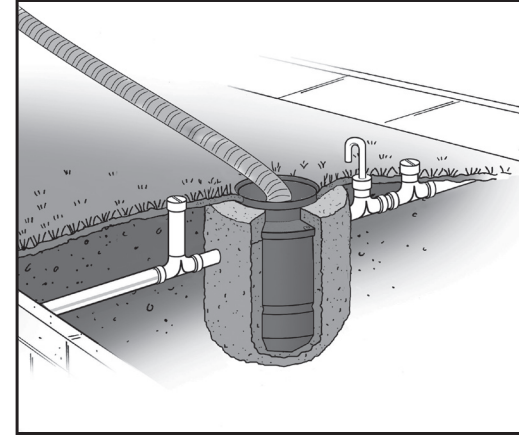

The Grease or Solids building up inside the Trapzilla unit may be gauged using a Sludge Judge or similar device.

Note:

- 1) **Do NOT use mechanical crust breaking devices to break down any mat that has formed inside the Trapzilla Solids Separator.**
- 2) **Remove the four brass nuts from the bolts and fully remove the lid to pump out.**
- 3) **It is not necessary to remove adapter lid (ring) to pump out the Trapzilla Solids Separator.**

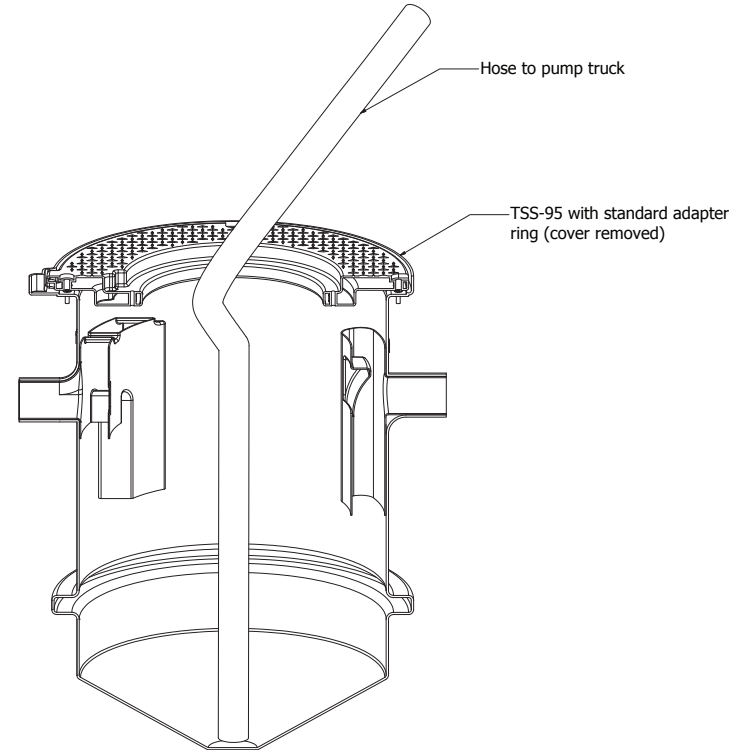

Drop hose into Solids Separator, pumping out all liquids and solids in the unit. It may be necessary to use water hose to rinse out chamber.

8.0 Limited Warranty & Remedy

Thermaco, Inc. warrants to the original user that the equipment manufactured by Thermaco and delivered with this warranty (the "Product") shall be free from material defects in workmanship and materials during the lifetime of the plumbing system in which the Product is initially installed.

Any claim under this warranty must be made in writing to Thermaco at 646 Greensboro Street, Asheboro, NC 27203 promptly after discovery of the defect and the Product must be delivered, prepaid, to Thermaco, together with proof of purchase and a return authorization number issued by Thermaco. If Thermaco determines that the Product is defective, Thermaco's sole obligation, and the purchaser's sole and exclusive remedy, is the repair or replacement, at Thermaco's option, of the defective Product.

This warranty shall not cover any defect or damage resulting directly or indirectly from: (i) failure to properly install, operate or maintain the Product in accordance with Thermaco's instructions, including, without limitation, use in excess of rated flow, installation deeper than manufacturer's recommendation or in conjunction with unapproved components, use to remove emulsified fats and oils or use that fails to comply with applicable laws, regulations or codes; (ii) damage in transit, handling or installation; (iii) modifications, adjustments, or alterations of the Product; (iv) disassembly of components other than as required for prescribed maintenance; or (v) any other causes not arising out of defects in workmanship or materials. Thermaco shall not be responsible for damage to Products resulting from ultraviolet light exposure, vault flooding, sewer line back-up, pumping or lift station failure, ambient water flow, freezing, or other sources of water damage. Costs for any service, adjustment, removal, repair, packing, or otherwise incurred with respect to the Product prior to submission for warranty are the responsibility of purchaser.

No distributor, sales representative or other person is authorized to make any warranty statements on behalf of Thermaco regarding Products other than as provided herein. This statement of warranty supersedes any quote, brochure, or other statement or document with respect to warranty of Thermaco products.

EXCEPT AS EXPRESSLY SET FORTH ABOVE, THERMACO MAKES NO REPRESENTATIONS, WARRANTIES OR GUARANTEES, EITHER EXPRESSED OR IMPLIED, INCLUDING, WITHOUT LIMITATION, AS TO MERCHANTABILITY OR FITNESS FOR A PARTICULAR PURPOSE, WHETHER OR NOT THERMACO HAD KNOWLEDGE OF PURCHASER'S PARTICULAR REQUIREMENTS OR NEEDS, OR WITH RESPECT TO ODOR GENERATION OR OTHER INCIDENTALS RELATING TO USE OF THE PRODUCT.

The sole and exclusive remedy with respect to this warranty or any other claim relating to defects or any other condition or use of Products, however caused, and whether such claim is based upon warranty, contract, tort, strict liability or any other theory, is LIMITED to the repair or replacement of the Product, excluding any cost to remove or install the Product or, at Thermaco's option, repayment of the purchase price. IN NO EVENT SHALL THERMACO BE LIABLE, WHETHER IN CONTRACT, WARRANTY, TORT (INCLUDING NEGLIGENCE), STRICT LIABILITY, INDEMNITY OR ANY OTHER LEGAL THEORY, FOR INCIDENTAL OR CONSEQUENTIAL DAMAGES. UNDER NO CIRCUMSTANCES WILL THE AGGREGATE LIABILITY OF THERMACO FOR ANY CAUSE OF ACTION RELATED TO THE PRODUCT COVERED HEREBY EXCEED THE NET PURCHASE PRICE RECEIVED BY THERMACO FOR THE PRODUCT.